

# Furling Mechanisms

**3626**

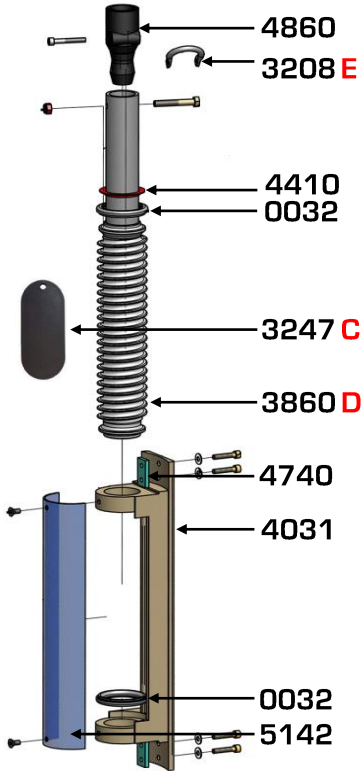

**Z300E -  
Z532E**

**3627/3001**

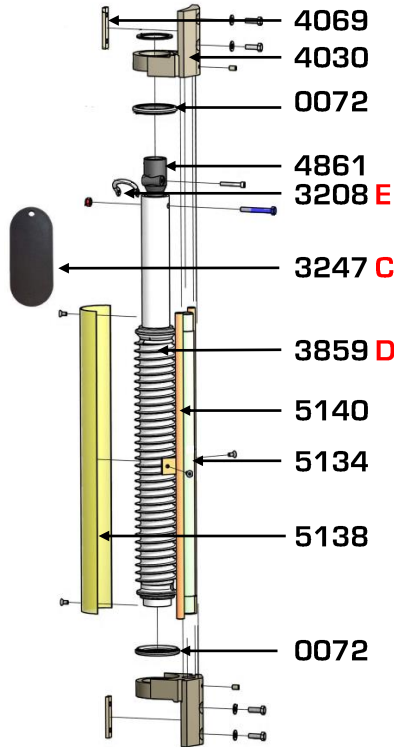

**Z600E - Z1100E /  
Z602E - Z902E**

**3367**

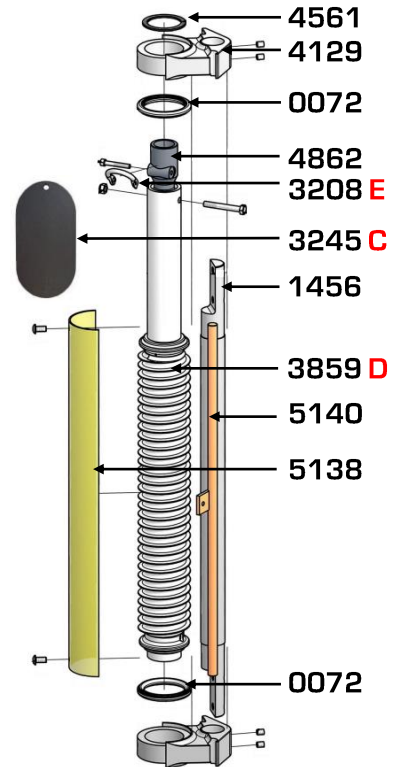

**Z1252E -  
Z1400E**

**Halyard Swivels**

**A**



**3168 F**



**Z55 Furling Extrusion**

**B**



Section		Z300E	Z400E	Z500E	Z600E/ Z602E	Z700E/ Z702E	Z900E/ Z902E	Z1100E
Halyard Swivel	<b>A</b>	3504	3164	3164	3165	3165	3166	3159
Furling Extrusion	<b>B</b>	Z55	Z55	Z55	Z55	Z55	Z55	Z55
Maintenance Cap	<b>C</b>	3247	3247	3247	3245	3245	3245	3245
Furling Wormdrive	<b>D</b>	3860	3860	3860	3859	3859	3859	3859
Clew Shackle	<b>E</b>	3208	3208	3208	3208	3208	3208	3208
Halyard Shackle	<b>F</b>	3168	3168	3168	3168	3168	3168	1562
Complete Furling Unit		3626	3626	3626	3627	3627	3627	3627